

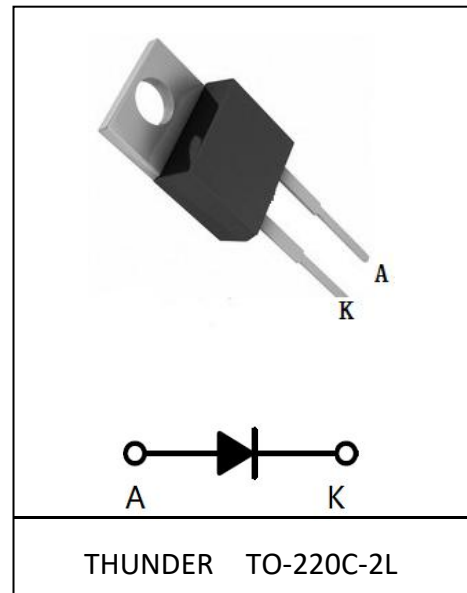
## FRED

### Ultrafast Soft Recovery Diode, 6A

**Features:**

- Ultrafast Recovery
- 175°C operating junction temperature
- High frequency operation
- Low power loss, less RFI and EMI
- Low  $I_R$  value
- High surge capacity
- Epitaxial chip construction

| Product Summary |       |
|-----------------|-------|
| $V_R$           | 600 V |
| $I_{F(AV)}$     | 6A    |
| $t_{rr}$        | 24ns  |


**Description/Applications**

These diodes are optimized to less losses and EMI/RFI in high frequency power conditioning system. The soft recovery behavior of the diodes offers the need as snubber in most applications. These devices are ideally suited for HF welding power converters and other applications where the switching losses are not significant portion of the total losses.

**Absolute Maximum Ratings**

| Parameter                          | Symbol      | Test Conditions           | Values      | Unit             |
|------------------------------------|-------------|---------------------------|-------------|------------------|
| Repetitive peak reverse voltage    | $V_{RRM}$   |                           | 600         | V                |
| Continuous forward current         | $I_{F(AV)}$ | $T_c = 110^\circ\text{C}$ | 6           | A                |
| Single pulse forward current       | $I_{FSM}$   | $T_c = 25^\circ\text{C}$  | 80          |                  |
| Maximum repetitive forward current | $I_{FRM}$   | Square wave, 20kHz        | 10          |                  |
| Operating junction                 | $T_j$       |                           | 150         | $^\circ\text{C}$ |
| Storage temperatures               | $T_{stg}$   |                           | -55 to +150 | $^\circ\text{C}$ |

**Electrical characteristics (Ta=25°C unless otherwise specified)**

| Parameter                             | Symbol              | Test Conditions                     | Min. | Typ. | Max. | Unit    |
|---------------------------------------|---------------------|-------------------------------------|------|------|------|---------|
| Breakdown voltage<br>Blocking voltage | $V_{BR}$ ,<br>$V_R$ | $I_R=100\mu A$                      | 600  |      |      | V       |
| Forward voltage<br>(Per Diode)        | $V_F$               | $I_F=6A, T_j=25^\circ C$            |      | 1.5  | 1.9  |         |
|                                       |                     | $I_F=6A, T_j=125^\circ C$           |      | 1.2  | 1.7  |         |
| Reverse leakage<br>current(Per Diode) | $I_R$               | $V_R=V_{RRM}, T_j=25^\circ C$       |      |      | 1    | $\mu A$ |
|                                       |                     | $T_j=150^\circ C, V_R=600V$         |      |      | 200  |         |
| Reverse recovery<br>time(Per Diode)   | $t_{rr}$            | $I_F=0.5A, I_R=1A, I_{RR}=0.25A$    |      | 35   | 50   | ns      |
|                                       |                     | $I_F=1A, V_R=30V, di/dt=200A/\mu s$ |      | 24   | 30   |         |

**Thermal characteristics**

| Paramter         | Symbol          | Typ. | Unit         |
|------------------|-----------------|------|--------------|
| Junction-to-Case | $R_{\theta JC}$ | 4.0  | $^\circ C/W$ |

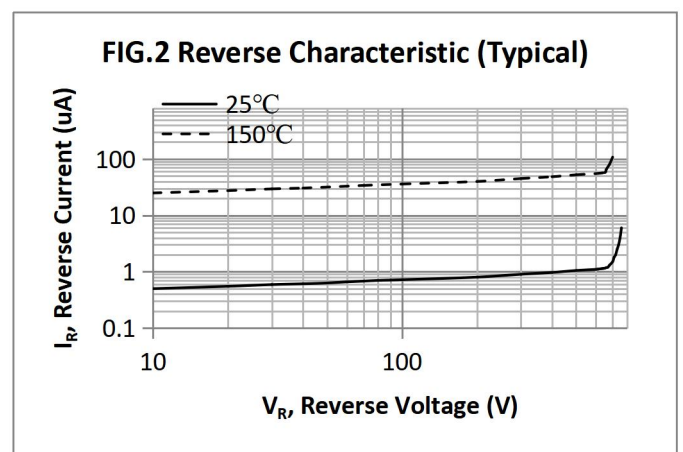
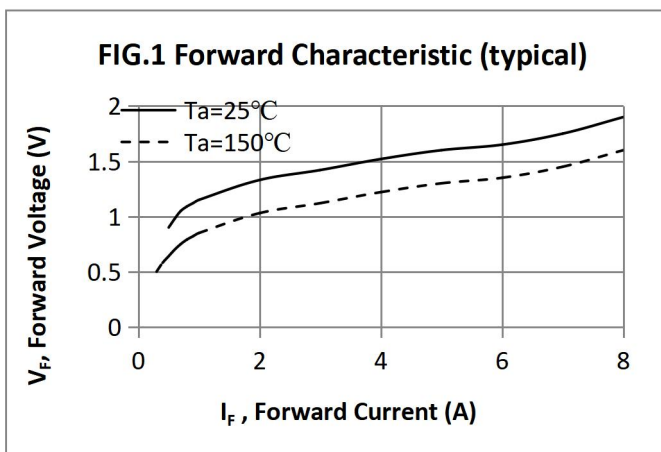
**Electrical performance (typical)**


FIG.3 Reverse Recover Time vs. Current Rate of Change

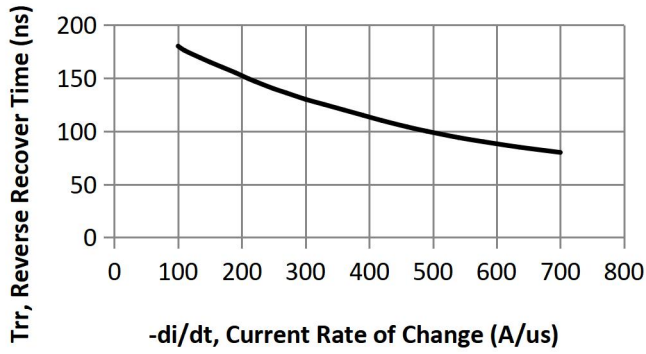


FIG.4 Reverse Recover Charge vs. Current Rate of Change

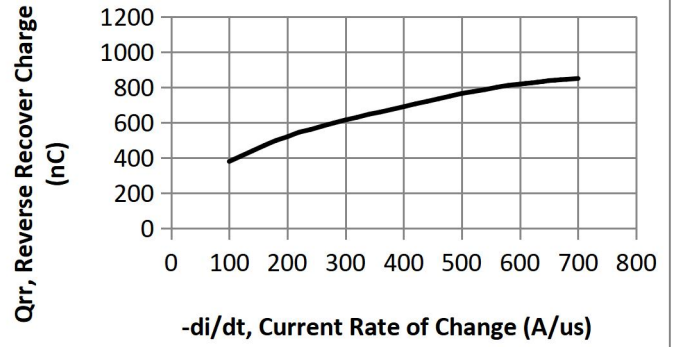


FIG.5 Reverse Recover Current vs. Current Rate of Change

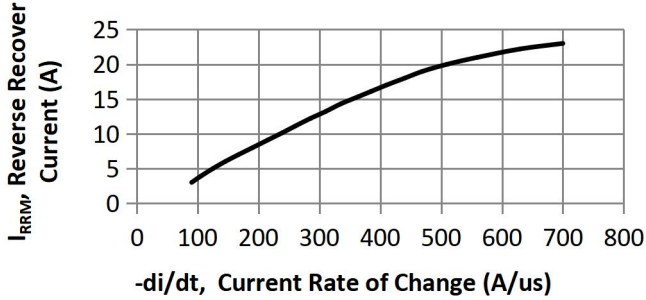


FIG.6 Average Forward Current vs. Case Temperature

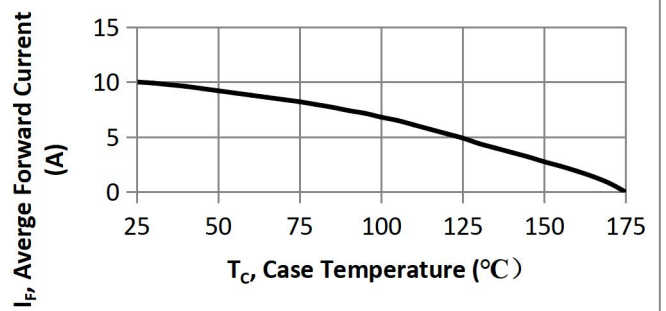
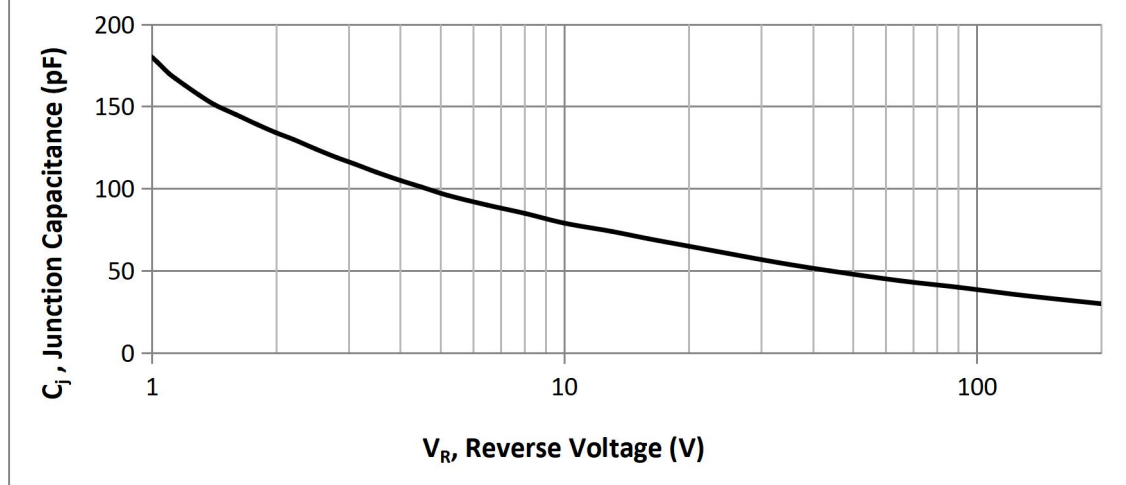


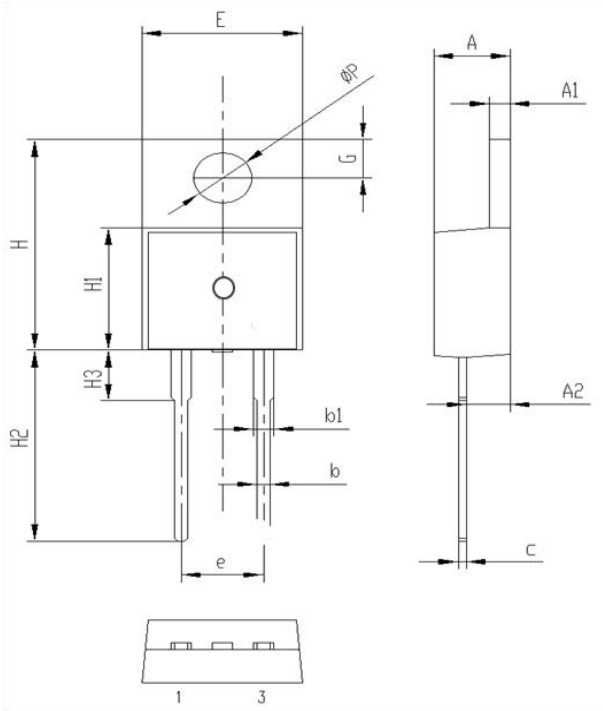
FIG.7 Junction Capacitance vs. Reverse Voltage



## Package Information

### TO-220C-2L PACKAGE

#### 基本尺寸



| Symbol | 单位 mm |      |      |
|--------|-------|------|------|
|        | Min   | Nom  | Max  |
| A      | 4.30  | 4.50 | 4.70 |
| A1     | 1.2   | 1.3  | 1.4  |
| A2     | 2.30  | 2.40 | 2.50 |
| b      | 0.60  | 0.8  | 1.00 |
| b1     | 1.15  | 1.35 | 1.55 |
| c      | 0.40  | 0.50 | 0.60 |
| e      | 4.88  | 5.08 | 5.28 |
| E      | 9.8   | 10.0 | 10.2 |
| H      | 15.5  | 15.7 | 15.9 |
| H1     | 9.00  | 9.20 | 9.40 |
| H2     | 12.5  | 13.0 | 13.5 |
| H3     | 2.80  | 3.0  | 3.20 |
| G      | 2.60  | 2.8  | 3.00 |
| ΦP     | 3.40  | 3.6  | 3.80 |

## Notice

Thunder Microelectronics Incorporated Limited reserves the right to make changes without further notice to any products or specifications herein. When use the product, be sure to obtain the latest specification.

Thunder Microelectronics Incorporated Limited does not assume any liability arising out of the application or any product described herein. When using Thunder Microelectronics Incorporated Limited products in your equipment, you are requested to take adequate safety measures to prevent the equipment from causing a physical injury ,fire or other problem if any of the products become faulty.

### -Headquarters

WuXi Thunder Microelectronics Incorporated Limited

Building E1-9, No.200 LingHu Road, XinWu district,WuXi,China 214135

Tel:+86-510-85160109

Fax:+86-510-85160109