

Silicon Field Stop(FS) Trench IGBT

Description

The THG50T65FQKH is use advanced field stop(FS) technology. The 650V FS IGBT offers superior conduction and switching performances.

General Features

- 650V Breakdown Voltage
- Low saturation voltage: $V_{CE(sat), typ}=2.3V@I_C=50A$ and $T_C=25^{\circ}C$
- FS Trench Technology, Positive temperature coefficient

Application

- Solar Converters
- Welding Converters
- UPS

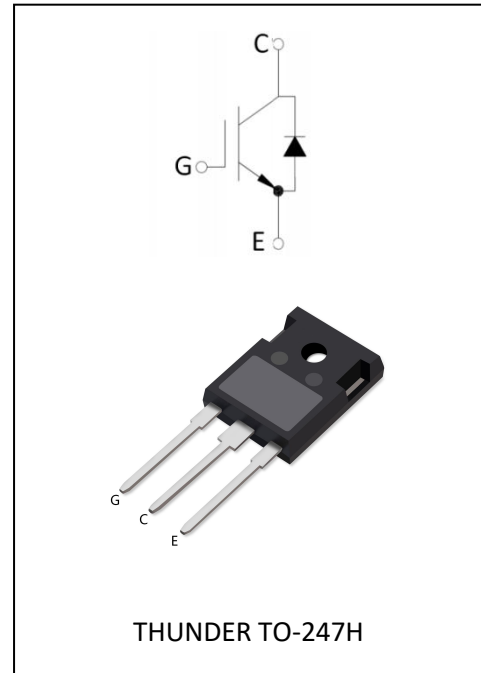

Electrical Characteristics @ $T_C=25^{\circ}C$ (unless otherwise specified)

a) Limited Parameters:

Symbol	Parameter	Value	Unit
V_{CES}	Collector-Emitter Voltage	650	V
V_{GES}	Gate-Emitter Voltage	+/-20	V
I_C	Collector Current	100	A
	Collector Current @ $T_C=100^{\circ}C$	50	A
I_{CM}	Pulsed Collector Current	150	A
I_F	Diode Continuous Forward Current @ $T_C=100^{\circ}C$	50	A
I_{FM}	Diode Maximum Forward Current	100	A
P_D	Total Dissipation at @ $T_C=100^{\circ}C$	300	W
	Total Dissipation at @ $T_a=25^{\circ}C$	600	
T_j	Operating Junction and Storage Temperature Range	-55 to +175	$^{\circ}C$
T_L	Max Temperature For Soldering	260	$^{\circ}C$
T_{SC}	Short circuit data $V_{GE}=15V, V_{CC} \leq 360V, T_{vj}=150^{\circ}C$	5	us

b) Electrical Parameters:

Symbol	Parameter	Test Conditions	Min	Typ	Max	Unit
V_{CES}	Collector-Emitter Voltage	$V_{GE}=0V, I_{CE}=250\mu A$	650			V
$V_{CE(sat)}$	Collector-Emitter Saturation Voltage	$V_{GE}=15V, I_C=50A$		2.3	2.8	V
$V_{GE(th)}$	Gated Threshold Voltage	$V_{CE}=V_{GE}, I_C=1mA$	4.0	5.0	6.0	V
I_{CES}	Collector-Emitter Leakage Current	$V_{GE}=0V, V_{CE}=650V$			10	μA
$I_{GES(F)}$	Gate to Emitter Forward Leakage	$V_{GE}=+20V,$			250	nA
$I_{GES(R)}$	Gate to Emitter Reverse Leakage	$V_{GE}=-20V,$			-250	nA
C_{ies}	Input Capacitance	$V_{GE}=0V,$ $V_{CE}=30V,$ $f=1.0MHz$		3820		pF
C_{oes}	Output Capacitance			218		pF
C_{res}	Reverse Transfer Capacitance			42		pF
Q_g	Total Gate Charge		$V_{CE}=400V$		125	
Q_{ge}	Gate to Emitter Charge	$I_C=50A$		29		nC
Q_{gc}	Gate to Collector Charge	$V_{GE}=15V$		50		nC

Symbol	Parameter	Test Conditions	Min	Typ	Max	Unit
$t_{d(on)}$	Turn-on Delay Time	$V_{CE}=400V, I_C=50A$ $V_{GE}=15V, R_G=10\Omega$		141		nS
t_r	Rise Time			98		nS
$t_{d(off)}$	Turn-off Delay Time			345		nS
t_f	Fall Time			99		nS
E_{on}	Turn-on Energy			4.3		mJ
E_{off}	Turn-off Energy			0.5		mJ
E_{tot}	Total Switching Energy			4.8		mJ

Symbol	Parameter	Test Conditions	Min	Typ	Max	Unit
I_F	Diode Continuous Forward Current	$TC=100^\circ C$	50			A
I_{FM}	Diode Maximum Forward Current	$TC=100^\circ C$	100			A
V_F	Diode Forward Voltage	$I_F=50A$		1.56	2.3	V
t_{rr}	Reverse Recovery Time	$T_J=25^\circ C, I_F=50A$ $di/dt=200A/us$		55		nS
Q_{rr}	Reverse Recovery Charge			198		nC
I_{RRM}	Reverse Recovery Current			5.9		A
*Pulse Test: Pulse Width $\leq 300\mu s$, Duty Cycle $\leq 2\%$						

Symbol	Paramter	Typ	Max	Unit
$R_{\theta JC}$	Themal Resistance,Junction to case for IGBT	--	0.343	$^{\circ}\text{C}/\text{W}$
$R_{\theta C}$	Themal Resistance,Junction to case for Diode	--	0.47	$^{\circ}\text{C}/\text{W}$
$R_{\theta JA}$	Themal Resistance,Junction to Ambient	--	40	$^{\circ}\text{C}/\text{W}$

Typical Performance Characteristics

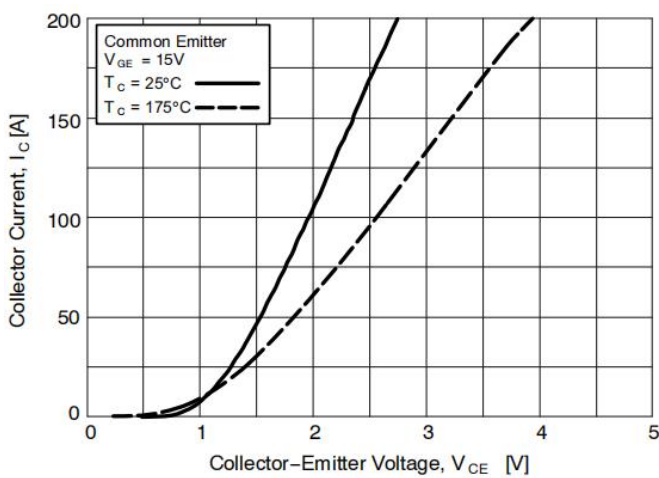

Figure 3. Typical Saturation Voltage

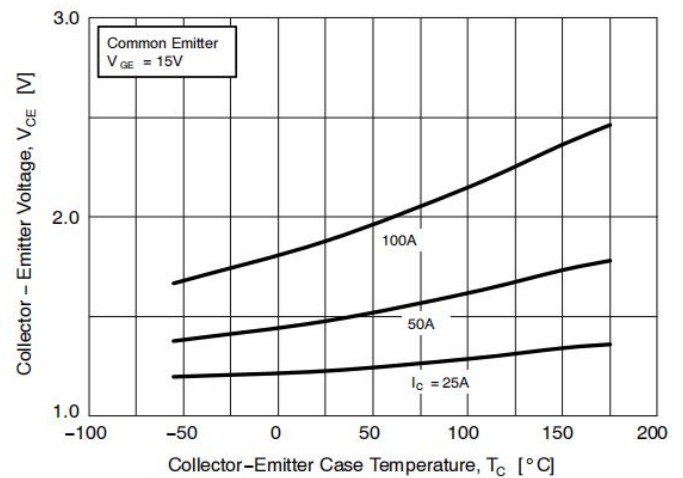

Figure 4. Saturation Voltage vs. Case Temperature

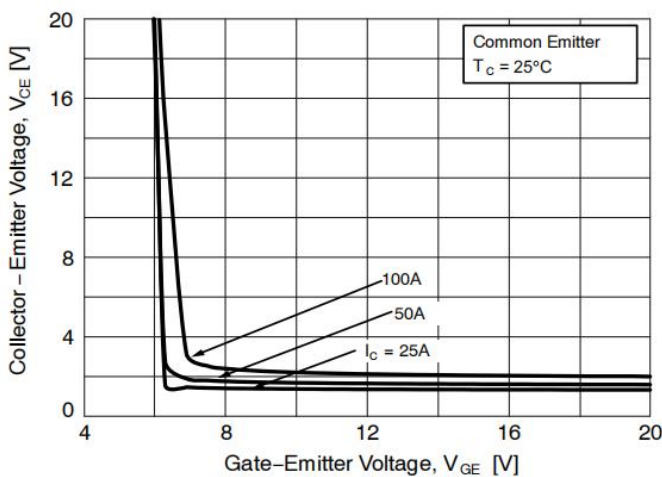

Figure 5. Saturation Voltage vs. V_{GE}

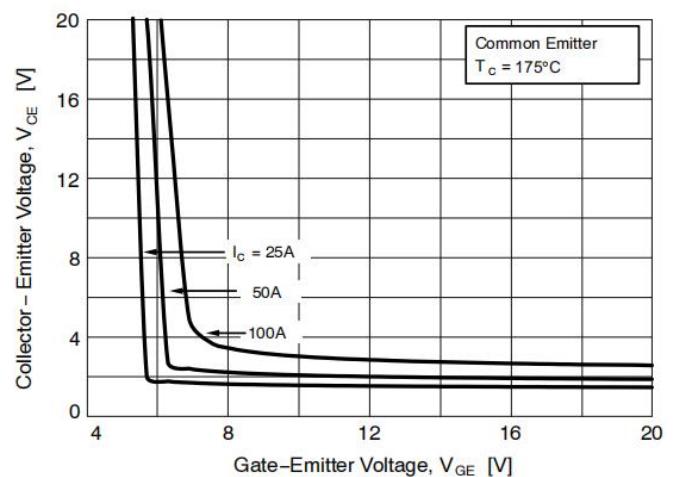

Figure 6. Saturation Voltage vs. V_{GE}

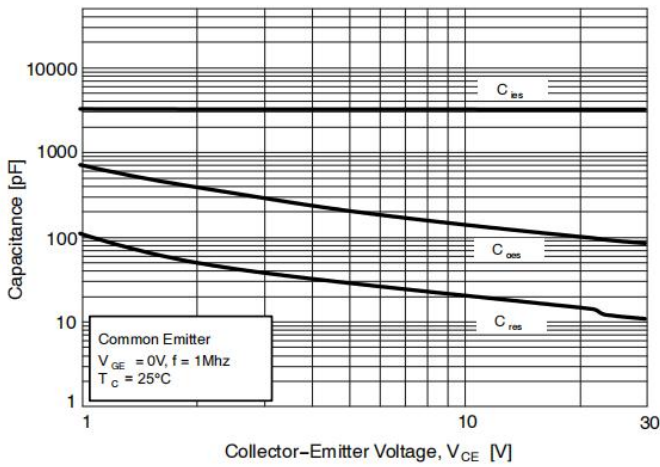

Figure 7. Capacitance Characteristics

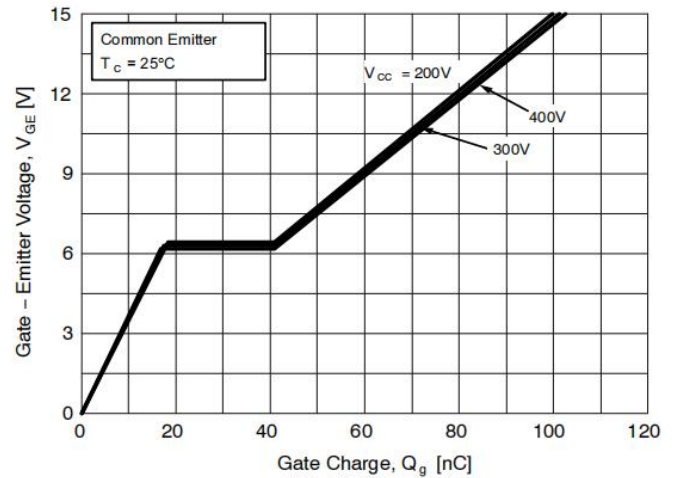

Figure 8. Gate Charge

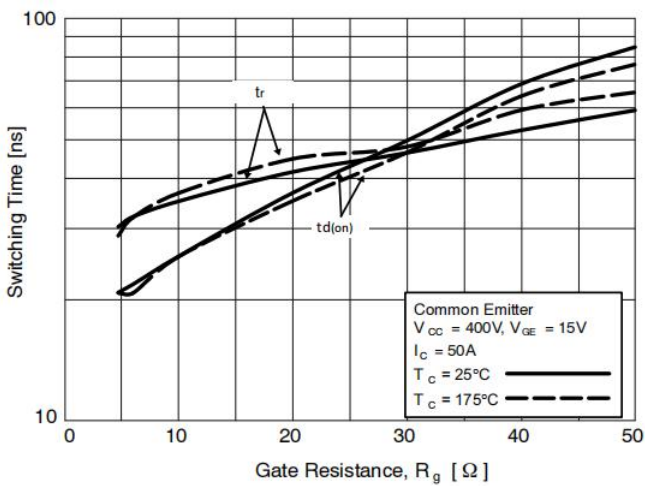

Figure 9. Turn-On Characteristics vs. Gate Resistance

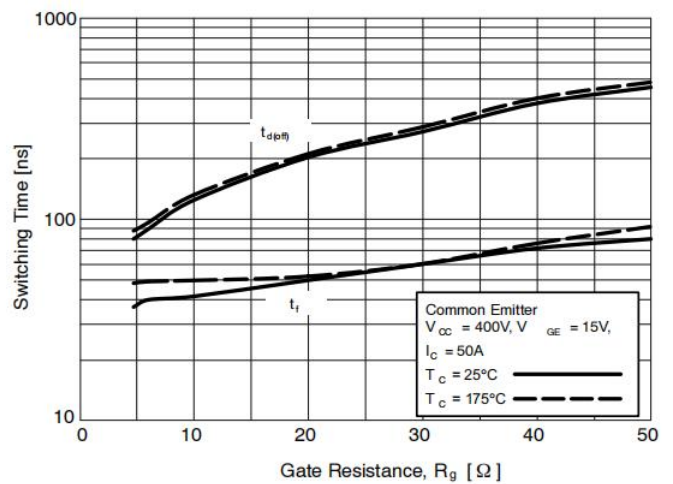

Figure 10. Turn-Off Characteristics vs. Gate Resistance

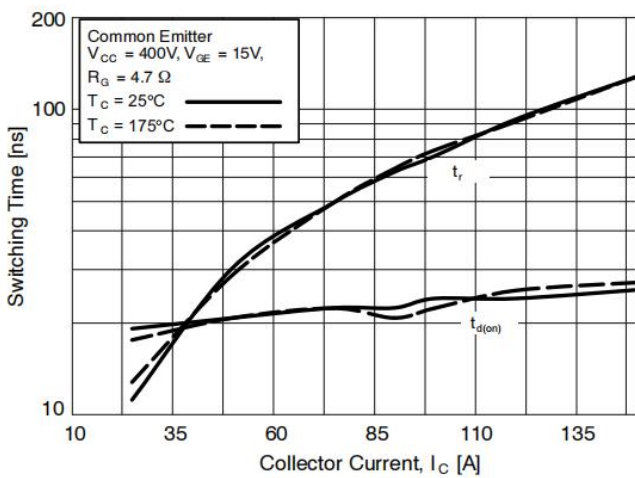

Figure 11. Turn-On Characteristics vs. Collector Current

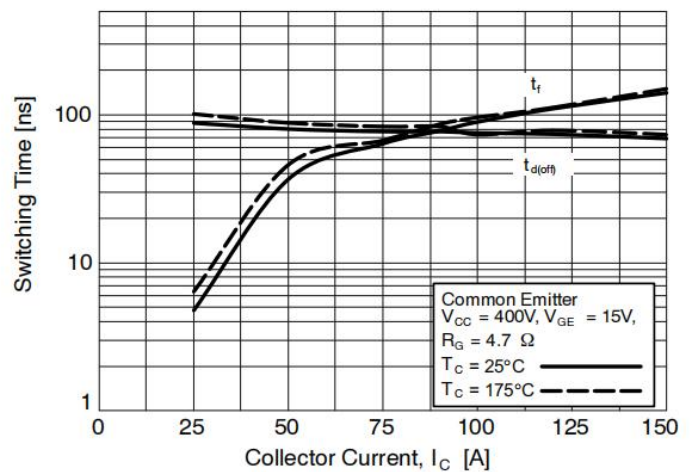

Figure 12. Turn-Off Characteristics vs. Collector Current

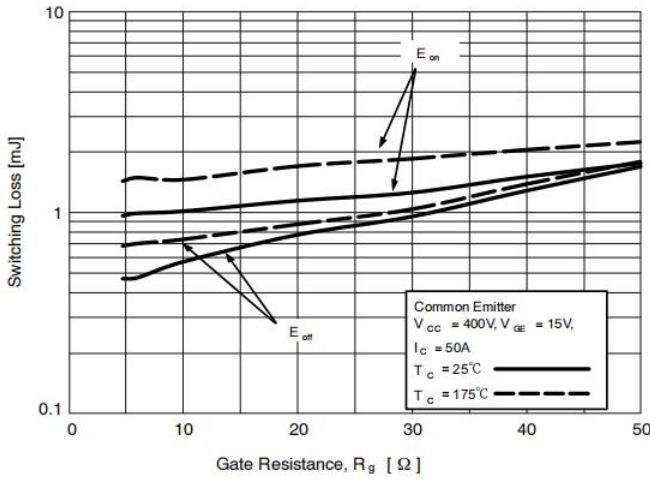

Figure 13. Switching Loss vs. Gate Resistance

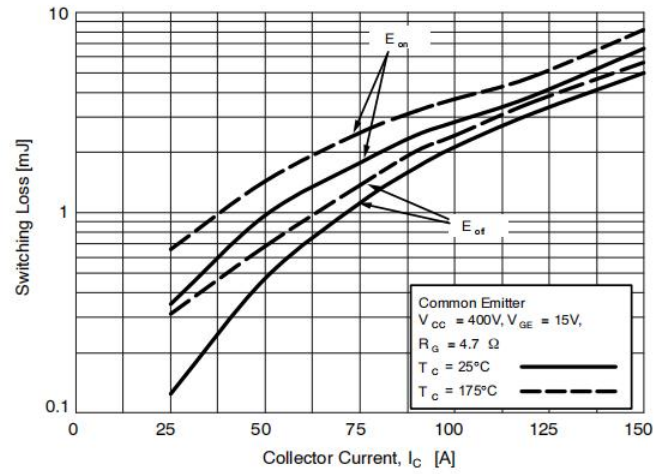

Figure 14. Switching Loss vs. Collector Current

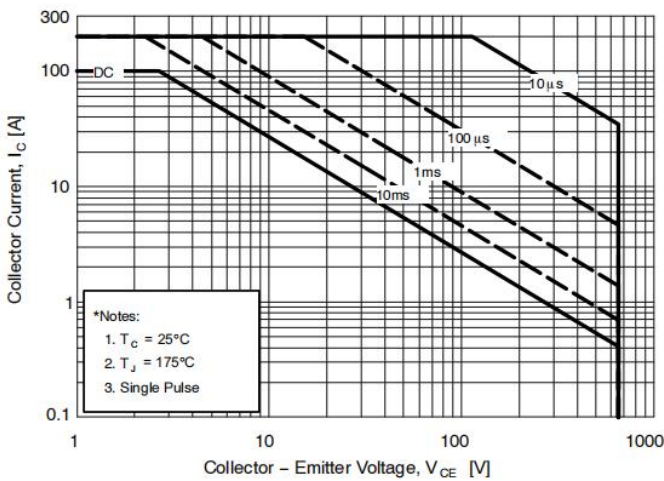

Figure 15. SOA Characteristics

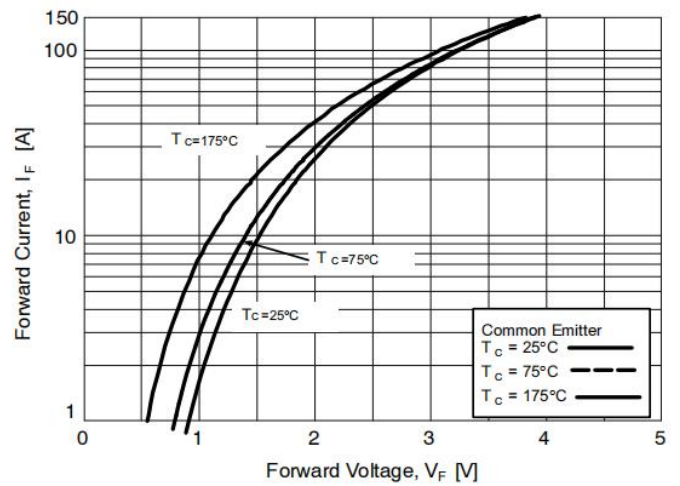

Figure 16. Forward Characteristics

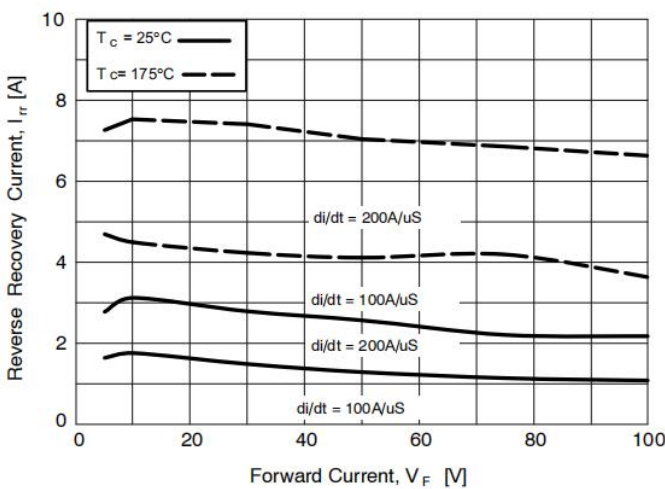

Figure 17. Reverse Recovery Current

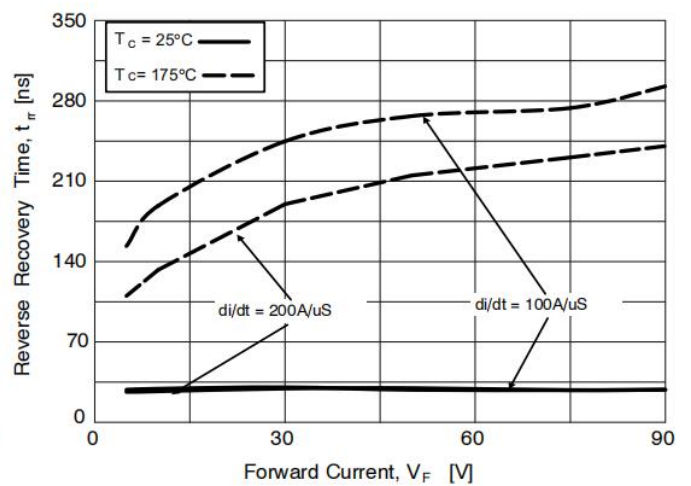

Figure 18. Reverse Recovery Time

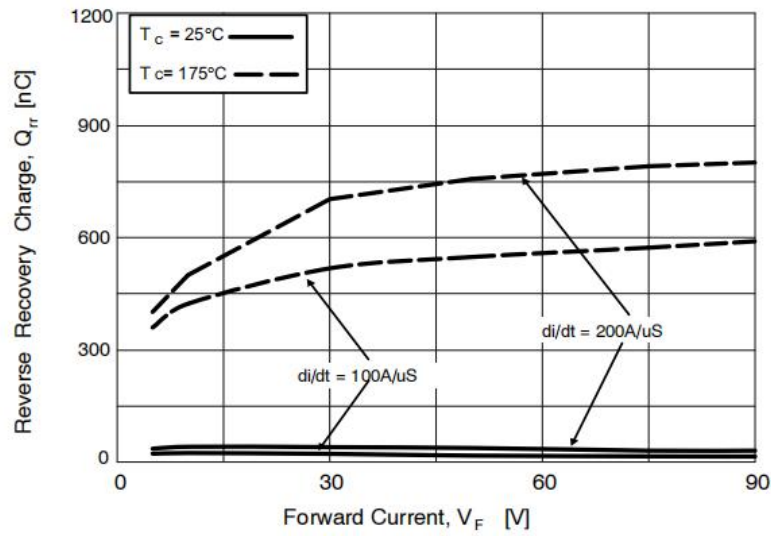

Figure 19. Stored Charge

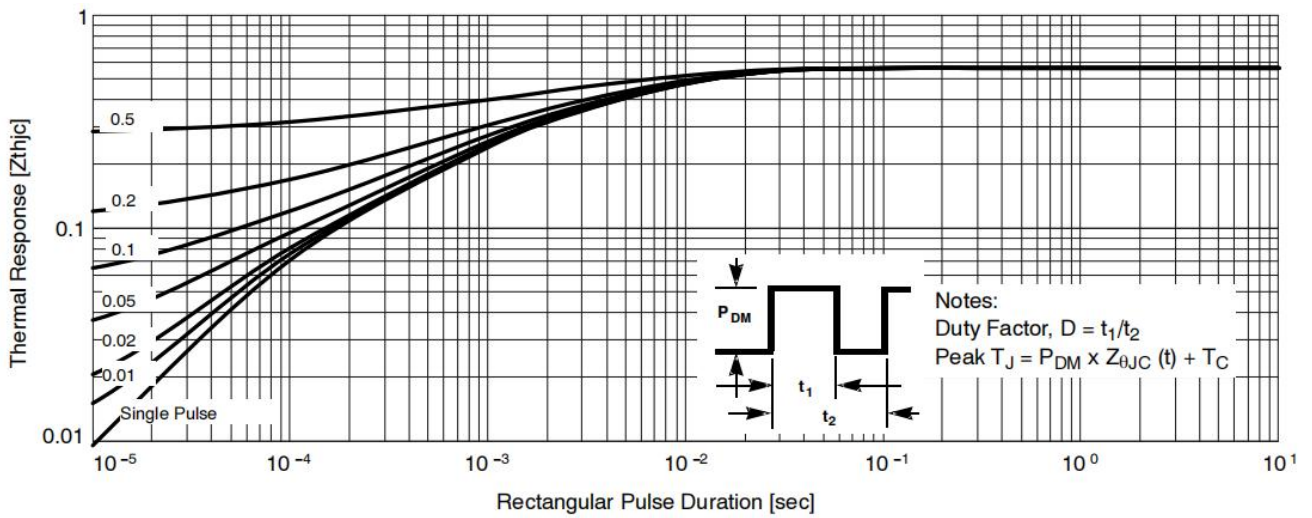

Figure 20. Transient Thermal Impedance of IGBT

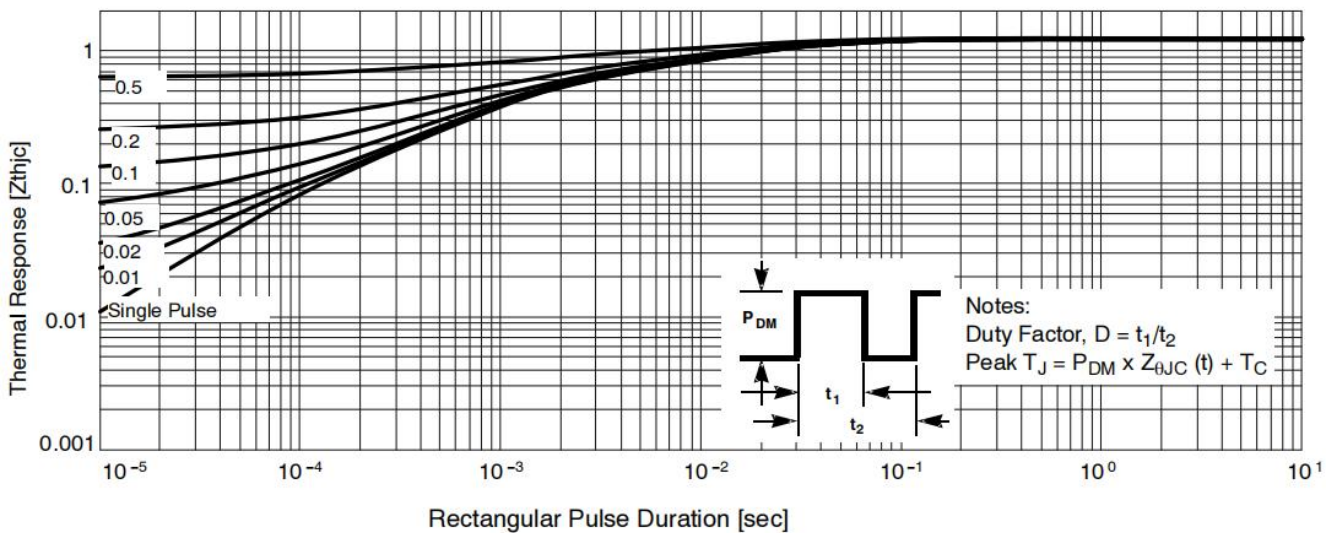
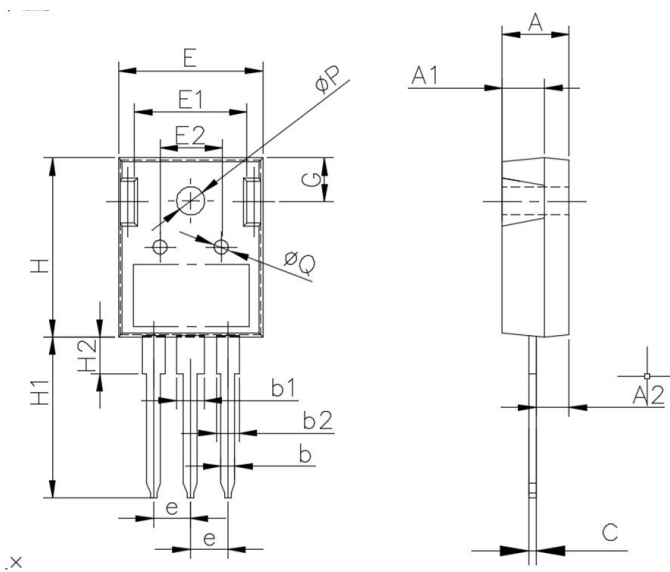

Figure 21. Transient Thermal Impedance of Diode

Package Information

TO-247H PACKAGE

基本尺寸



Symbol	单位 mm		
	Min	Nom	Max
A	4.80	5.00	5.20
A1	2.80	3.00	3.20
A2	2.20	2.40	2.60
b	1.05	1.20	1.35
b1	2.80	3.00	3.20
b2	1.80	2.00	2.20
c	0.50	0.60	0.70
e	5.35	5.45	5.75
E	15.6	15.80	16.0
E1	12.3	12.50	12.7
E2	6.00	6.20	6.40
H	20.8	21.0	21.2
H1	19.5	20.0	20.5
H2	3.70	4.00	4.30
G	5.70	5.90	6.10
ΦP	3.30	3.50	3.70
ΦQ	2.30	2.50	2.70

Notice

Thunder Microelectronics Incorporated Limited reserves the right to make changes without further notice to any products or specifications herein. When use the product, be sure to obtain the latest specification.

Thunder Microelectronics Incorporated Limited does not assume any liability arising out of the application or any product described herein. When using Thunder Microelectronics Incorporated Limited products in your equipment, you are requested to take adequate safety measures to prevent the equipment from causing a physical injury ,fire or other problem if any of the products become faulty.

-Headquarters

WuXi Thunder Microelectronics Incorporated Limited
 Building E1-9, No.200 LingHu Road, XinWu district,WuXi,China 214135
 Tel:+86-510-85160109 Fax:+86-510-85160109